*MONOBLOC
RANGE SUMMARY*

PowerSafe[®] Vb batteries are vented lead-acid batteries designed for industrial applications in power supply with high safety requirements. These monoblocs can be used for both long duration discharge (hours) and short duration discharge (minutes). The main areas of application are DC power supply systems in power stations and substations, UPS systems, industrial systems and emergency power supply systems. They can also be used for engine starting and for energy storage in solar power systems.

The special rod plate design of PowerSafe Vb batteries offers a high energy density and a long life time in one unique design. This gives better performance and can minimise the use of valuable floor space. Built-in transport handles on the lid allied with the unique PowerSafe Vb safety pole terminals make this a superior battery design. A long topping up interval minimises service requirements to complete the package.

Features

- Capacity range: 50 – 246Ah
- 6V and 12V monoblocs
- Water topping up interval about 3 years in standby operation mode at 20°C
- Long service life due to proven PowerSafe rod plate technology and PowerSafe safety plugs
- Cover for vent plugs and transport handles integrated in battery lid, plain side walls
- Optimised plate design results in increased capacity of 20% to 35% in DIN containers



Construction

- Positive electrode - Rod plate with low antimony lead alloy. Proven design and radial grid structure ensure superior long-term behaviour
- Negative electrode - Pasted grid plate
- Separation - Microporous separator, combined with glass fibre mat
- Container material - Specially modified, impact resistant, clear acrylonitrile-butadiene-styrene (ABS), with electrolyte level indication
- Electrolyte - Dilute sulphuric acid. Low specific gravity (1.24kg/l) for long lasting and reliable performance
- Terminal design - Leak-proof safety pole with brass insert and M8 stainless steel bolt

- Vent plugs - Proven design as standard. Spray eliminating, flame arresting and 'easy fill' plugs available as options
- Connectors - Solid copper connector (20mm x 3mm) insulated, bolted type, voltage measurement possible

- Batteries must be installed in accordance with EN 50272-2, IEC 62485-2 and national regulations
- Recommended operating temperature range: +10°C to +30°C (preferred value 20°C)

Installation & Operation

- Float charge voltage: 2.23Vpc at 20°C
- Suitable for all standard types of installation
- Small floor area required for installation due to high energy density
- For use in earthquake zones special approved racks are available

Standards

- Conforms to IEC 60896-11
- Product Standard for reference DIN 40739 (OGI monobloc batteries)
- Manufactured in ISO 9001:2008 certified production facilities

General Specifications

Battery Type	Nominal Voltage (V)	Nominal Capacity (Ah)		Nominal Dimensions						Typical Weight		Electrolyte Volume S.G. = 1.240		Short Circuit Current (A)	Internal Resistance (mΩ)
		10 hr rate to 1.80Vpc @ 20°C	8 hr rate to 1.75Vpc @ 77°F	Length mm	in	Width mm	in	Height ⁽¹⁾ mm	in	kg	lbs	litres	US gallon		
Vb 12143	12	50	50	221	8.7	176	6.9	277	10.9	24.8	54.7	4.3	1.2	1490	8.1
Vb 12144	12	66	66	311	12.2	176	6.9	277	10.9	33.7	74.3	6.3	1.7	1960	6.1
Vb 12146	12	100	100	389	15.3	176	6.9	277	10.9	45.6	100.5	7.9	2.1	2930	4.1
Vb 12147	12	117	117	469	18.5	176	6.9	277	10.9	53.5	118.2	9.7	2.6	3430	3.5
Vb 12149	12	150	150	553	21.8	176	6.9	277	10.9	65.5	144.4	11.7	3.1	4400	2.7
Vb 6157	6	191	191	284	11.2	229	9.0	332	13.0	45.8	101.0	10.1	2.7	3600	1.7
Vb 6159	6	246	246	284	11.2	229	9.0	332	13.0	51.6	113.8	9.2	2.5	4610	1.3

The electrical values shown in the table relate to loadings from a fully charged condition at ambient temperature of 20°C (unless otherwise specified).

⁽¹⁾Height includes connector.

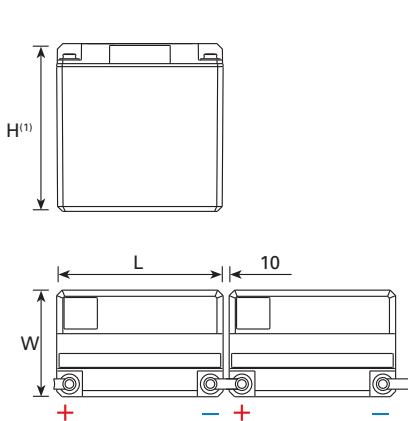

Vb 12143 - Vb 12149

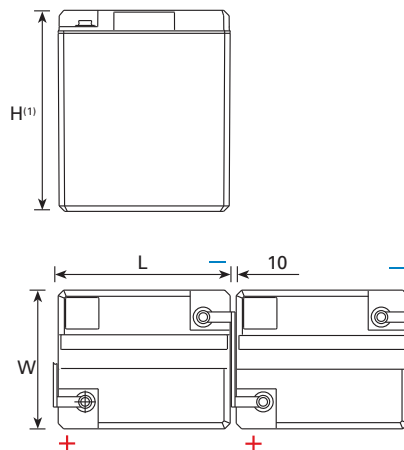

Vb 6157 & Vb 6159



www.enersys-emea.com

EnerSys
P.O. Box 14145
Reading, PA 19612-4145
USA
Tel: +1-610-208-1991
+1-800-538-3627
Fax: +1-610-372-8613

EnerSys Europe
Löwenstrasse 32
8001 Zurich, Switzerland

EnerSys Asia
152 Beach Road
Gateway East Building, Level 11
189721 Singapore
Tel: +65 6508 1780

EnerSys Ltd.
Oak Court
Clifton Business Park
Wynne Avenue, Swinton
Manchester M27 8FF
UK
Tel: +44 (0)161 794 4611
Fax: +44 (0)161 727 3809

Contact:

© 2011 EnerSys®. All rights reserved.
Trademarks and logos are the property of EnerSys® and its affiliates unless otherwise noted.