

DataSafe[®] UPS-H batteries are vented lead-acid batteries developed for the specific requirements of uninterruptible power supply (UPS) systems. These monoblocs are suitable for short duration discharge at high power loads. Due to their high power density DataSafe UPS-H batteries are especially suitable for use in UPS systems where space and volume saving accommodation is required. DataSafe UPS-H batteries are mainly used in computer centres and in systems for automation and process control.

The special rod plate design of DataSafe UPS-H batteries offers a high energy density and a long life time in one unique design. This gives better performance and minimises the use of valuable space. Built-in transport handles on the lid allied with the unique DataSafe safety pole terminals make this a superior battery design. A long topping up interval minimises service requirements to complete the package.

Features

- Capacity range: 172 – 822 Wpc
- 6V and 12V monoblocs
- Suitable for fast recharge
- High operational safety
- Supply of ready installed UPS batteries on stands or in cabinets with integrated battery fuse box BAE (battery fuse and disconnect unit).
- Topping up intervals of about 3 years in standby parallel operation mode at 20°C
- Vent plugs and handles integrated into cover



Construction

- Positive electrode - Rod plate with low antimony lead alloy
- Negative electrode - Pasted grid plate
- Separation - Microporous separator, combined with glass fibre mat
- Container material - Specially modified, impact resistant, clear acrylonitrile-butadiene-styrene (ABS), with electrolyte level indication
- Electrolyte - Dilute sulphuric acid, density = 1.28 kg/l
- Terminal design - Leak-proof safety pole with brass insert and M8 stainless steel bolt

- Vent plugs - Proven design as standard. Spray eliminating, flame arresting and 'easy fill' plugs available as options
- Connectors - Solid copper connector (20mm x 3mm) insulated, bolted type, voltage measurement possible

- Batteries must be installed in accordance with EN 50272-2, IEC 62485-2 and national regulations
- Recommended operating temperature range: +10°C to +30°C (preferred value 20°C)

Installation & Operation

- Float charge voltage: 2.25Vpc at 20°C
- Suitable for all standard types of installation
- Small floor area required for installations due to high energy density
- For use in earthquake zones special approved racks are available

Standards

- Conforms to IEC 60896-11
- Product Standard for reference DIN 40739 (OGI monobloc batteries)
- Manufactured in ISO 9001: 2008 certified production facilities

General Specifications

Battery Type	Nominal Voltage (V)	Nominal Capacity (Ah)		Nominal Dimensions						Typical Weight		Electrolyte Volume S.G. = 1.280		Short Circuit Current (A)	Internal Resistance (mΩ)
		10 hr rate to 1.80Vpc @ 20°C	15 min rate to 1.67Vpc @ 25°C	Length		Width		Height ⁽¹⁾		kg	lbs	litres	US gallon		
UPS 108 H	12	57	172	221	8.7	176	6.9	277	10.9	24.8	54.7	4.3	1.2	1500	8.1
UPS 144 H	12	76	229	311	12.2	176	6.9	277	10.9	33.7	74.3	6.3	1.7	2000	6.1
UPS 216 H	12	114	344	389	15.3	176	6.9	277	10.9	45.6	100.5	7.9	2.1	3000	4.1
UPS 252 H	12	133	401	469	18.5	176	6.9	277	10.9	53.5	118.2	9.7	2.6	3500	3.5
UPS 324 H	12	171	515	553	21.8	176	6.9	277	10.9	65.5	144.4	11.7	3.1	4500	2.7
UPS 378 H	6	208	644	284	11.2	229	9.0	332	13.0	45.8	101.0	10.1	2.7	3770	1.6
UPS 486 H	6	268	822	284	11.2	229	9.0	332	13.0	51.6	113.8	9.2	2.5	4850	1.3

The electrical values shown in the table relate to loadings from a fully charged condition at ambient temperature of 20°C (unless otherwise specified).

⁽¹⁾Height includes connector.

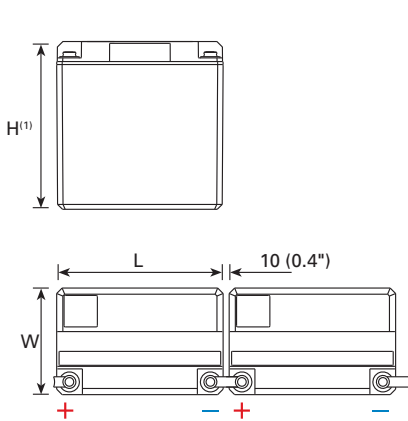

UPS 108 H - UPS 324 H

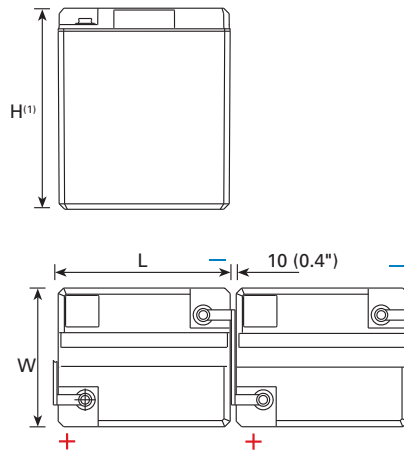

UPS 378 H & UPS 486 H



www.enersys-emea.com

EnerSys
 P.O. Box 14145
 Reading, PA 19612-4145
 USA
 Tel: +1-610-208-1991
 +1-800-538-3627
 Fax: +1-610-372-8613

EnerSys Europe
 Löwenstrasse 32
 8001 Zurich, Switzerland

EnerSys Asia
 152 Beach Road
 Gateway East Building, Level 11
 189721 Singapore
 Tel: +65 6508 1780

EnerSys Ltd.
 Oak Court
 Clifton Business Park
 Wynne Avenue, Swinton
 Manchester M27 8FF
 UK
 Tel: +44 (0)161 794 4611
 Fax: +44 (0)161 727 3809

Contact:

© 2011 EnerSys®. All rights reserved. Trademarks and logos are the property of EnerSys® and its affiliates unless otherwise noted.