

RANGE SUMMARY

The PowerSafe™ DDm range of valve regulated lead acid batteries further demonstrates EnerSys' commitment to supplying those high quality products demanded by customers in the Reserve Power marketplace. PowerSafe DDm combines the benefits of large capacity, long life cells with a choice of compact racking systems to provide reliable, cost-effective solutions for large installations.

PowerSafe DDm's enhanced cell design incorporates thick positive plates for superior operational life expectancy together with a dual pillar seal arrangement for utmost integrity. Furthermore, cells are supplied in dedicated steel containers that maintain the uniform compression necessary to ensure consistent performance throughout product life.

The combination of individual modules for easier handling and specially engineered conventional racks provide the flexibility for system design that allows simplified, front access installation even in the most difficult locations. Where operating criteria demands, PowerSafe DDm can also be supplied with seismic racks qualified to UBC 1997 Zone 4.

For those Reserve Power applications that include telecommunications, uninterruptible power supply and power generation/distribution, PowerSafe DDm provides an unrivalled solution.

Features & Benefits

- Up to 2000Ah in a single cell
- 100% initial battery capacity
- Flame retardant container & lid
- High integrity, dual pillar seal design
- Excellent design life
- Individual modules for maximum configuration flexibility
- Simple on-site installation process
- Total front access for easy maintenance



Construction

- Positive plates - Thick lead-tin-calcium grids minimise corrosion and prolong life
- Negative plates - Balanced lead-calcium grids optimise recombination efficiency
- Separators - Low resistance microporous glass fibre mat
- Electrolyte - Dilute sulphuric acid absorbed within the separator
- Cell box / lid - UL94 V0 flame retardant polypropylene
- Cell box - Single piece construction for optimum leak resistance

- Terminal pillar - Lead casting with threaded copper insert to provide maximum conductivity
- Pillar seal - 100% factory tested, proven ring burn with secondary epoxy resin seal
- Relief valve - Complete with integral flame arrestor

- Flexible configuration
- Total front access for easy maintenance
- Adjustable feet for uneven floors
- Top termination as standard
- Reduced maintenance: no water addition required

Installation & Operation

- Ease of installation due to module design concept. Simply set up rack and install modules

Standards

- Designed for compliance with IEC 60896-21/22
- All EnerSys production facilities are certified to ISO 9001:2000

General Specifications

Type	Cells per Module	Nominal Voltage (V)	Nominal Capacity (Ah)		Nominal Dimensions								Typical Weight			
			10hr. rate 1.80Vpc @ 20°C	8hr. rate 1.75Vpc @ 77°F	Length		Height		Depth (container)		Depth (module)		kg	lbs		
					mm	in	mm	in	mm	in	mm	in	mm	in		
2DDm50-09	2	4	200	200	188	7.4	165	6.5	333	13.1	366	14.4	34.3	75.4		
2DDm50-13	2	4	300	300	265	10.4	165	6.5	333	13.1	366	14.4	49.5	108.9		
DDm50-17	1	2	400	400	176	6.9	165	6.5	333	13.1	366	14.4	34.0	74.7		
2DDm85-13	2	4	510	510	265	10.4	165	6.5	519	20.4	554	21.8	75.7	166.5		
2DDm85-15	2	4	595	595	303	11.9	165	6.5	519	20.4	554	21.8	88.5	194.8		
DDm85-21	1	2	850	850	214	8.4	165	6.5	519	20.4	554	21.8	64.5	142.0		
DDm85-25	1	2	1020	1020	252	9.9	165	6.5	519	20.4	554	21.8	74.4	163.7		
DDm85-27	1	2	1105	1105	271	10.7	165	6.5	519	20.4	554	21.8	80.8	177.8		
DDm85-33	1	2	1360	1360	328	12.9	165	6.5	519	20.4	554	21.8	97.9	217.5		
DDm100-21	1	2	1000	1000	214	8.4	165	6.5	590	23.2	624	24.5	73.5	163.4		
DDm100-25	1	2	1200	1200	252	9.9	165	6.5	590	23.2	624	24.5	86.5	192.1		
DDm100-27	1	2	1300	1300	271	10.7	165	6.5	590	23.2	624	24.5	92.0	204.3		
DDm100-33	1	2	1600	1600	328	12.9	165	6.5	590	23.2	624	24.5	115.3	256.3		
DDm125-25	1	2	1500	1500	252	9.9	226	8.9	562	22.1	597	23.5	112.3	249.6		
DDm125-27	1	2	1625	1625	271	10.7	226	8.9	562	22.1	597	23.5	120.8	268.4		
DDm125-33	1	2	2000	2000	328	12.9	226	8.9	562	22.1	597	23.5	144.1	320.3		

Please contact your local EnerSys Sales Department for advice on how to select the most appropriate stand arrangement.

Typical 4 volt bloc

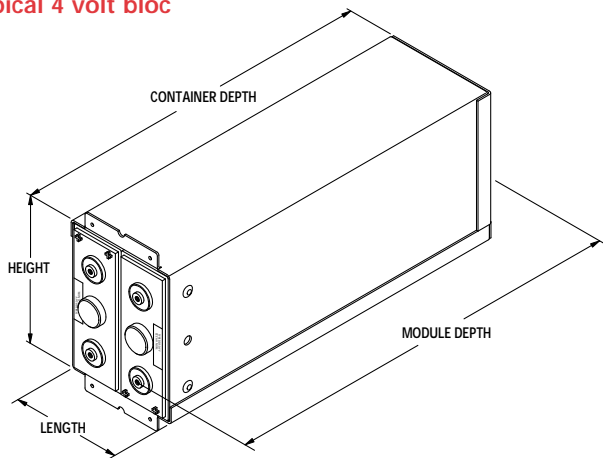

Typical 2 volt cell

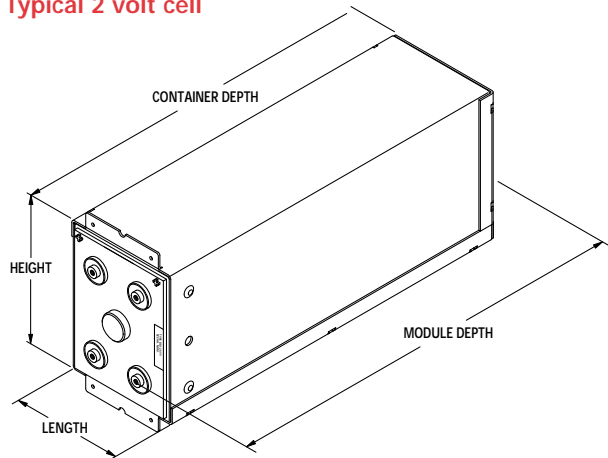

www.enersys-emea.com

EnerSys
P.O. Box 14145
Reading, PA 19612-4145
USA
Tel: +1-610-208-1991
+1-800-538-3627
Fax: +1-610-372-8613

EnerSys EMEA
Brussels, Belgium
Tel: +32 (0)2 247 94 47

EnerSys Asia
Guangdong, China
Tel: +86-755-2689 3639

EnerSys Limited
Rake Lane,
Clifton Junction,
Swinton, Manchester
M27 8LR, UK
Tel: +44 (0)161 794 4611
Fax: +44 (0)161 727 3809

Contact:

© 2007 EnerSys. All rights reserved.
Trademarks and logos are the property of EnerSys and its affiliates unless otherwise noted.